

# Sizing & Fit

The Lynn Vest is boxy, with a roomy fit and the hem hitting at the high hip. The vest is a layering piece. The deep armholes and ease allow for the vest to be worn over sweaters or loose-fitting tops, but it works equally well worn over T-shirts and dresses.

It is recommended to select your size based on your bust/chest measurement. For a closer fitting vest, you may consider sizing down.

If you fall between sizes or within two size ranges, it is recommended that you size down. If you fall between more than two sizes, select the middle size or review the **Fit Guide** on pages 8-10 for information on adjusting the fit to work for your body.

*Be sure to review the finished garment measurements before selecting your size.*

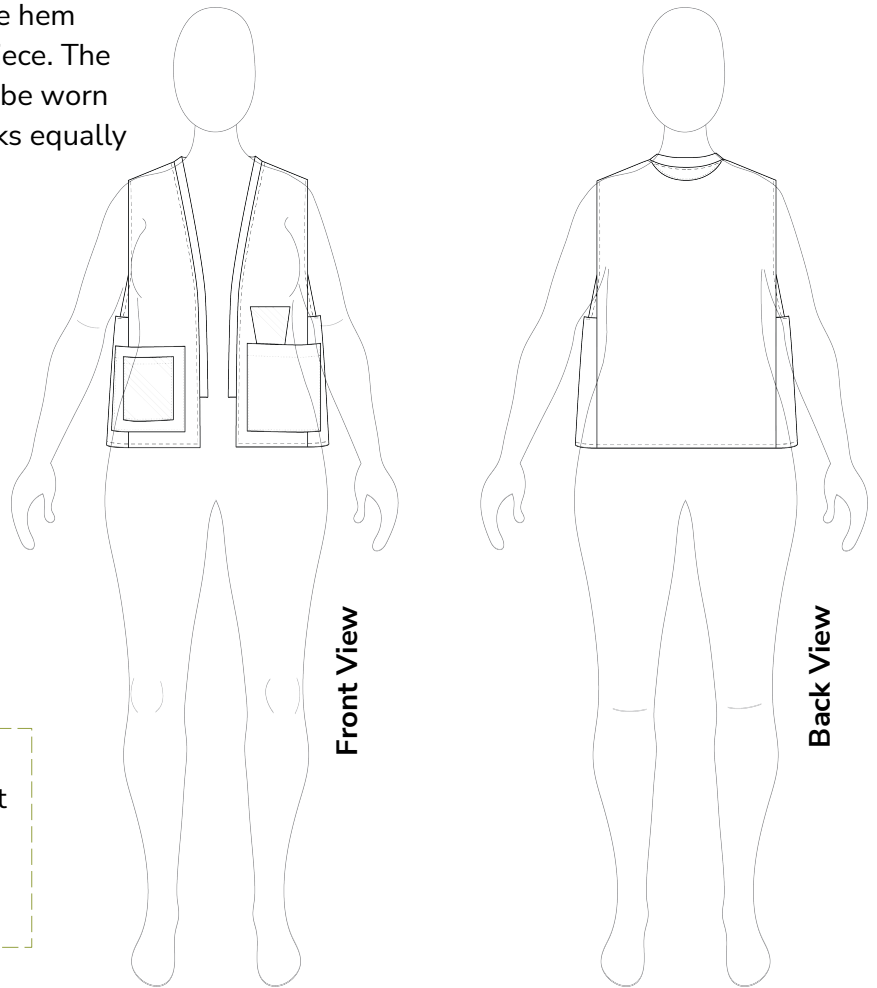

A quick toile/muslin using the following pattern pieces will give you an idea of fit before cutting into your final fabric:  
**FRONT PANELS, BACK PANEL, SIDE PANELS, UNDERARM GUSSETS**

## Body Measurements: INCHES (CENTIMETERS)

|          | Bust/Chest                 | Waist                      | Hip                        |
|----------|----------------------------|----------------------------|----------------------------|
| <b>A</b> | <b>30-32</b> (76.2-81.3)   | <b>24-26</b> (61-66)       | <b>32-34</b> (81.3-86.4)   |
| <b>B</b> | <b>34-36</b> (86.4-91.4)   | <b>28-30</b> (71.1-76.2)   | <b>36-38</b> (91.4-96.5)   |
| <b>C</b> | <b>38-40</b> (96.5-101.6)  | <b>32-34</b> (81.3-86.4)   | <b>40-42</b> (101.6-106.7) |
| <b>D</b> | <b>42-44</b> (106.7-111.8) | <b>36-38</b> (91.4-96.5)   | <b>44-46</b> (111.8-116.8) |
| <b>E</b> | <b>46-48</b> (116.8-121.9) | <b>40-42</b> (101.6-106.7) | <b>48-50</b> (121.9-127)   |
| <b>F</b> | <b>50-52</b> (127-132.1)   | <b>44-46</b> (111.8-116.8) | <b>52-54</b> (132.1-137.2) |
| <b>G</b> | <b>54-56</b> (137.2-142.2) | <b>48-50</b> (121.9-127)   | <b>56-58</b> (142.2-147.3) |
| <b>H</b> | <b>58-60</b> (147.3-152.4) | <b>52-54</b> (132.1-137.2) | <b>60-62</b> (152.4-157.5) |
| <b>I</b> | <b>62-64</b> (157.5-162.6) | <b>56-58</b> (142.2-147.3) | <b>64-66</b> (162.6-167.6) |
| <b>J</b> | <b>66-68</b> (167.6-172.7) | <b>60-62</b> (152.4-157.5) | <b>68-70</b> (172.7-177.8) |

Review **Finished Garment Measurements** on page 4 once you have selected your size. See **Fit Guide** on pages 8-10 for further fit information and guidance on how to make adjustments as needed.

# Sizing & Fit

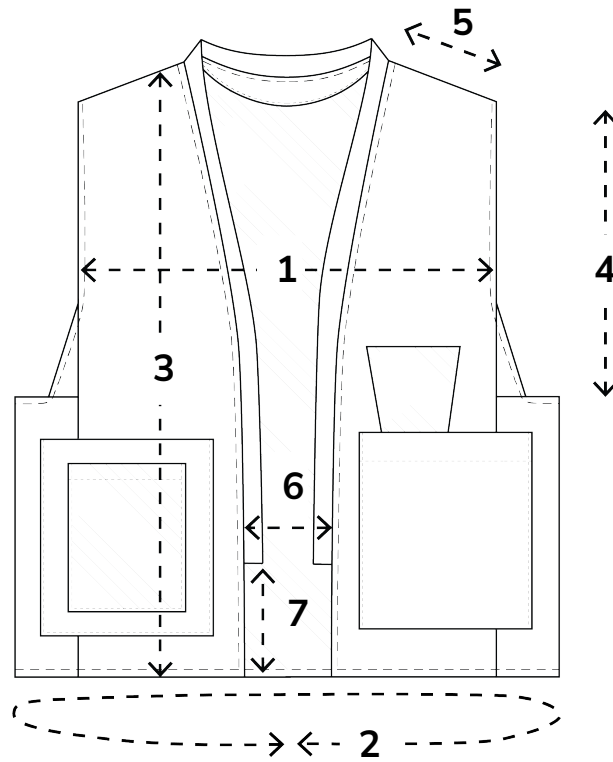

## Finished Garment Measurements INCHES (CENTIMETERS)

Drafted for a 5'6" (167.6cm) tall person

|   | 1. Chest/Bust* | 2. Hip**     | 3. Length   | 4. Armhole opening | 5. Shoulder Width | 6. Front Gap Width | 7. End of collar to hem |
|---|----------------|--------------|-------------|--------------------|-------------------|--------------------|-------------------------|
| A | 15 ¼ (38.7)    | 39 ½ (100.3) | 23 ¼ (59.1) | 11.5 (29.2)        | 3 ⅜ (8.6)         | 3 (7.6)            | 3 5/8 (9.2)             |
| B | 16 ¼ (41.3)    | 43 ½ (110.5) | 23 ¾ (60.3) | 11.5 (29.2)        | 3 13/16 (9.7)     | 3 (7.6)            | 4 1/6 (10.5)            |
| C | 17 ¼ (43.8)    | 47 ½ (120.7) | 24 ¼ (61.6) | 11.5 (29.2)        | 4 ¼ (10.8)        | 3 (7.6)            | 3 2/9 (8.2)             |
| D | 18 ¼ (46.4)    | 51 ½ (130.8) | 24 ¾ (62.9) | 11.5 (29.2)        | 4 11/16 (11.9)    | 3 (7.6)            | 3 7/9 (9.6)             |
| E | 19 ¼ (48.9)    | 55 ½ (141)   | 25 ¼ (64.1) | 11.5 (29.2)        | 5 ⅛ (13)          | 3 (7.6)            | 4 1/3 (11)              |
| F | 20 ¼ (51.4)    | 59 ½ (151.1) | 25 ¾ (65.4) | 11.5 (29.2)        | 5 9/16 (14.1)     | 3 (7.6)            | 4 6/7 (12.4)            |
| G | 21 ¼ (54)      | 63 ½ (161.3) | 26 ¼ (66.7) | 11.5 (29.2)        | 6 (15.2)          | 3 (7.6)            | 3 8/9 (9.6)             |
| H | 22 ¼ (56.5)    | 67 ½ (171.5) | 26 ¾ (67.9) | 11.5 (29.2)        | 6 7/16 (16.4)     | 3 (7.6)            | 4 ½ (11.4)              |
| I | 23 ¼ (59)      | 71 ½ (181.6) | 27 ¼ (69.2) | 11.5 (29.2)        | 6 ⅞ (17.5)        | 3 (7.6)            | 3 5/9 (9)               |
| J | 24 ¼ (61.6)    | 75 ½ (191.8) | 27 ¾ (70.5) | 11.5 (29.2)        | 7 5/16 (18.6)     | 3 (7.6)            | 4 1/9 (10.4)            |

\*Measurement taken flat. \*\*Front does not close, Hip measurement includes the space between the front panels when the garment is laying flat.